

A-A

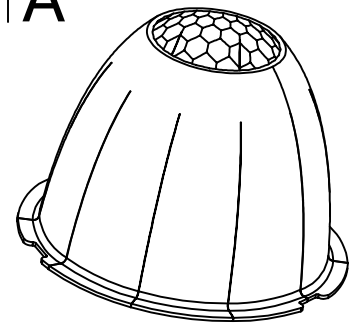
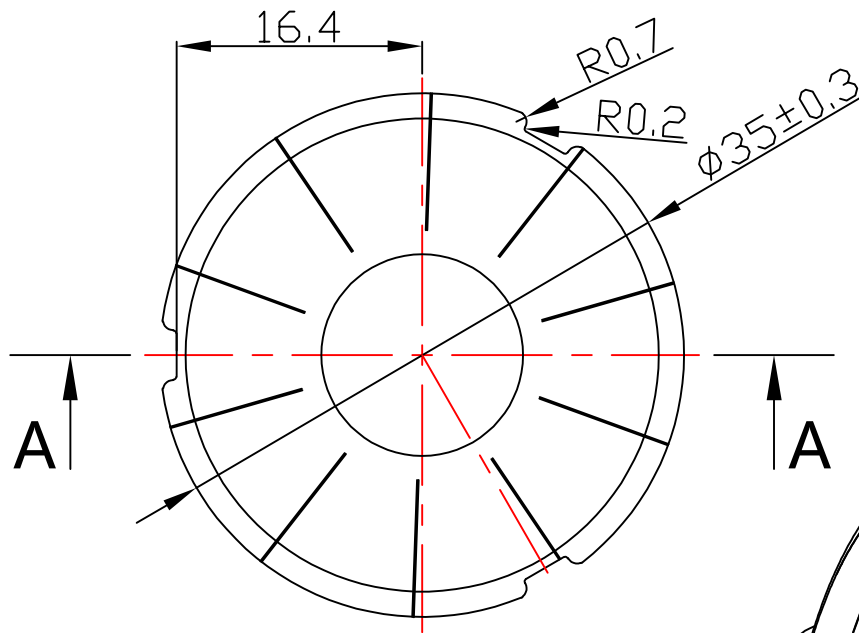

LIGHT SOURCE	LUMILEDS 1202HD
PLASTIC HOLDER	92.70.409.00
METAL ADAPTAR	
DESIGNED B.A.	$38^\circ \pm 3^\circ$
MEASURED B.A.	37°
EFFICIENCY	
光学装配示意图	

- Technical requirements:
- 1.MATERIAL: T=0.4mm High reflectivity aluminum(Mirror surface).
 - 2.**KEY CONTROL DIMENSION.
 - 3.Tolerances not noted are in accordance with the tolerance table.
 - 4.unmarked rounded corners Press for 3D.
 - 5.Surface without imprint, black spots, cracks, wrinkles and other poor.

标记 MARK	处数 NO.OF MODIF	更改内容 MODIFICATIONS	签名 SIGNED BY	更改日期 MODIF. DATE
设计 DESIGNER	制图 DRAWN BY	审核 CHECKED BY	比例 SCALE	1:1
工艺 TECHNICAN	日期 DATE(DD-MM-YYYY)	18-02-2022	视角 1st ANGLE PROJECTION	
批准 APPROVED BY	日期 DATE(DD-MM-YYYY)	18-02-2022	页数 PAGE	SHEET 1 OF 1

DIMENSION TOLERANCE TABLE (UNLESS OTHERWISE STATED)						
> 0-5	> 5-30	> 30-90	> 90-150	> 150-250	> 250-400	> 400-700
±0.15	±0.2	±0.4	±0.5	±0.8	±1.5	±2
PUNCH TOLERANCE TABLE (UNLESS OTHERWISE STATED) (ANGLE)						
> 0-10	> 10-50	> 50-120	> 120-250	> 250-360		
±1°	±0.5°	±0.3°	±0.2°	±0.166°		
产品图 PRODUCT DRAWING						
						单位 UNIT mm

Nata [®]		版本 VERSIONS K
产品编码 PRODUCT CODE	91.01.1273.000	
产品名称 PRODUCT NAME	1-1273-L	
客户代号 CUSTOMER ID	NT	
客户编号 CUSTOMER CODE	FA-35-38D	